

FI355M Flange Facer

27.2-355.6mm (1.07"-14")

YouTube



FI355M Manual Flange Facer is ideal for flange rush repair without any power source required. It is the most portable and easy to operate flange facer and perfect for re-facing raised-face and flat-faced flanges on site or in a fabrication/repair shop. The FI355M Flange Facer has a clamping range from 27.2mm to 270mm (1.07"-10.63") and can machine flanges up to 355.6mm (14") O.D.

The NODHA proprietary clamping system is simple to configure and designed for fast set up with accurate alignment. Cutting bits are double sided, long-lasting, and specially formed to cut through a wide variety of material including carbon steel, stainless steel, alloyed steel, aluminum and cast iron. Each tool kit comes ready to use in a sturdy carrying case that keeps everything conveniently organized and readily accessible.



Features

- Manual operated, no any power required
- Smooth swing operation produces perfectly precise phonographic finish
- Accurately mounts to I.D. in seconds, quick and easy set up
- Feeds available for both smooth and stock finish in accordance with ASME B-16.5
- Complete with kits ready to work
- Portable, durable trolley case, easy to storage and move

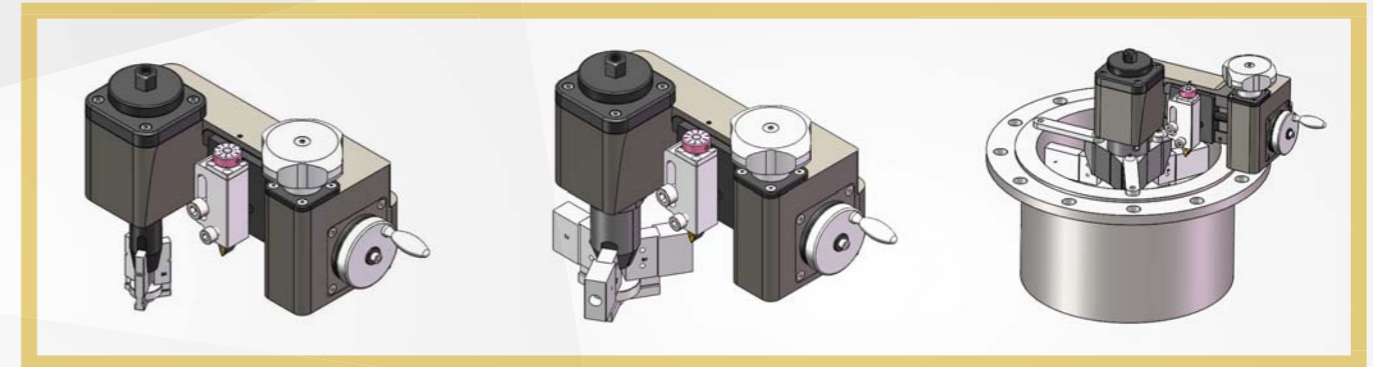

Three sizes of mounting chassis
covering Dia. 27.2-270mm
ensure stability during machining

Specifications

| Model | FI355M |
|-----------------------------|-------------------------|
| Driven | Manually |
| Min. Facing Dia. | 27.2mm / 1.07" |
| Max. Facing Dia. | 355.6mm / 14" |
| Min. Clamping Dia. | 27.2mm / 1.07" |
| Max. Clamping Dia. | 270mm / 10.63" |
| Tool Post Travel-Vertical | 40mm / 1.57" |
| Tool Post Travel-Horizontal | 57mm / 2.24" |
| Fine Finish-Feed Screw | 0.125mm/rev. / 0.005" |
| ASME B16.5-Feed Screw | 0.5mm/rev. / 0.02" |
| Swing Diameter range | 495-582mm / 19.5"-22.9" |
| Machine Weight | 9 Kgs |
| Shipping Weight | 29 Kgs |
| Package | Durable plastic case |
| Shipping Size | 680x510x250mm |

Dimension Figure

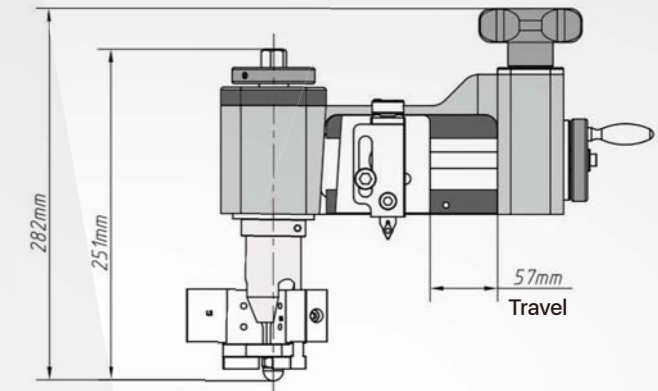
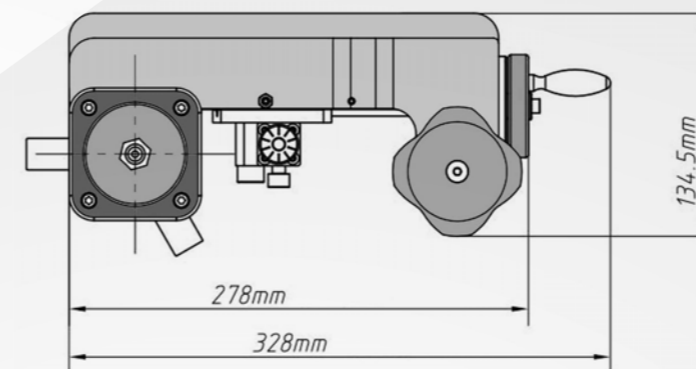

Standard Supply

| | |
|-----------------------|-------------------------------|
| Facer Body | Extention legs-N1, N2, N3, N4 |
| ASME B16.5 Lead Screw | Extention legs-B1, B2, B3, B4 |
| Straight Tool | Extention Legs-L1, L2, L3, L4 |
| 90° Tool (RH) | Spring- L 115mm |
| 90° Tool (LH) | Spring- L 300mm |
| Cutting tips - 10 pcs | Allen keys, set |
| Pull Rod -3 Nos | Spanner 17mm |
| S-Base | Plastic Hammer |
| M-Base | Dia Gauge |
| L-Base | Manual |

Package

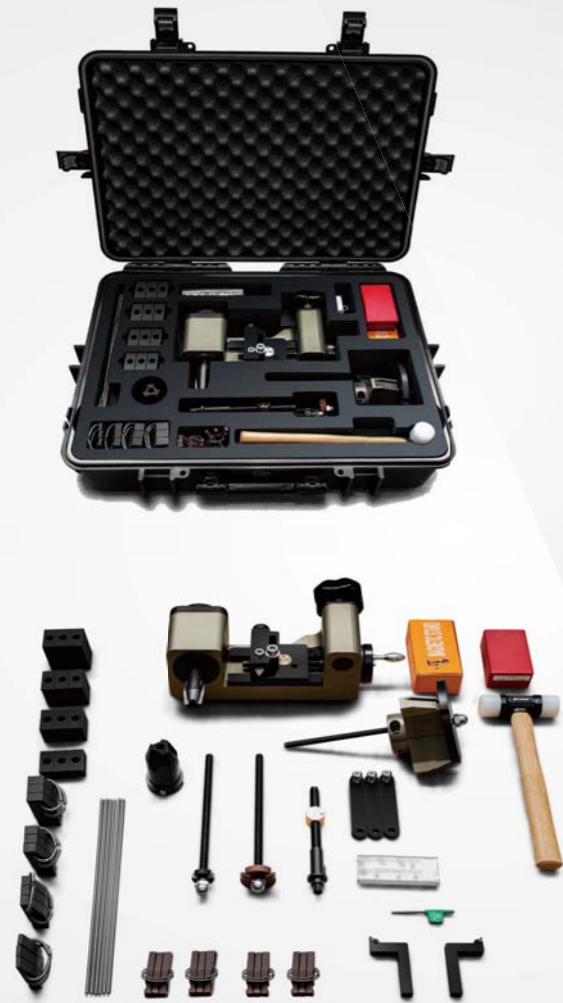

Configuration

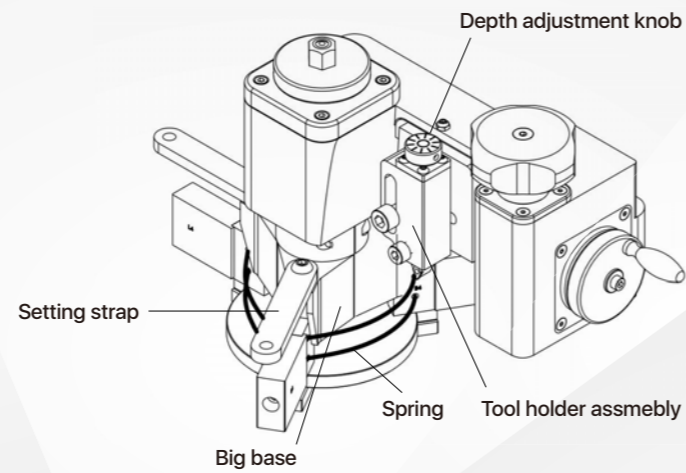
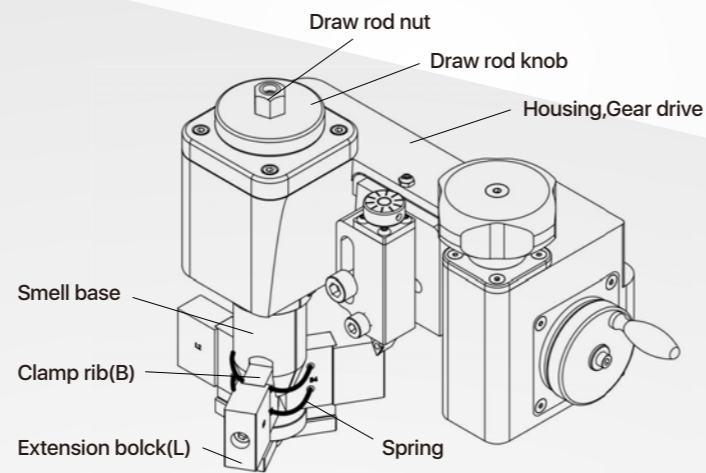
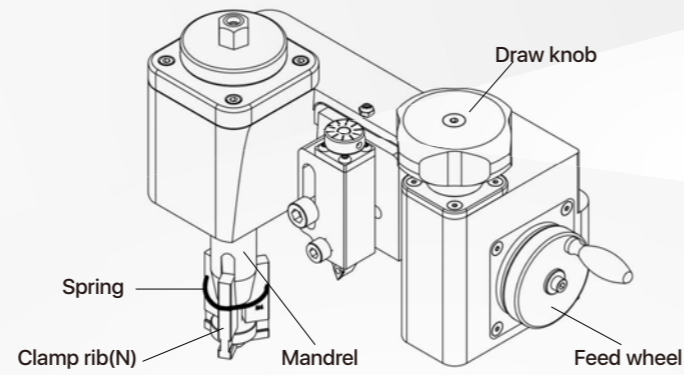

Application

